



CUSTOM SPECIFICATION DRAWING

ACO Polycrete Pty Ltd.
134-140 Old Bathurst Road
Emu Plains, NSW 2750
Tel: 02 4747 4000
Fax: 02 4747 4060
e: technical@acoaus.com.au

DRWG# VS1001
www.acoaus.com.au

System 100 - Vinyl Seal with End Outlet

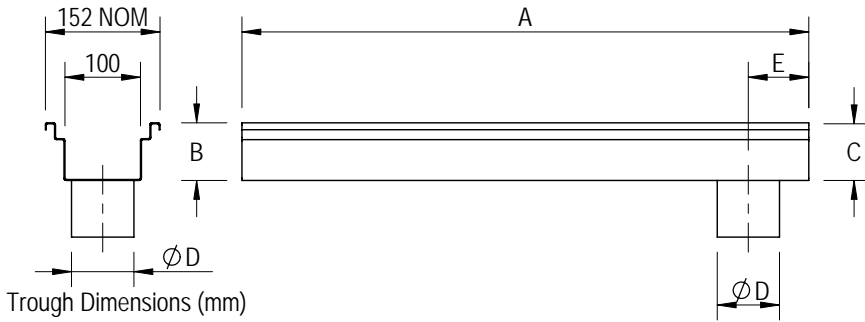

Required Information (enter details in space provided)		
A	Overall Length	mm
B	Upstream Overall Depth	mm
C	Downstream Overall Depth	mm
D	Outlet Diameter	mm
E	Outlet Location	mm

Endplate Options (select an endplate)

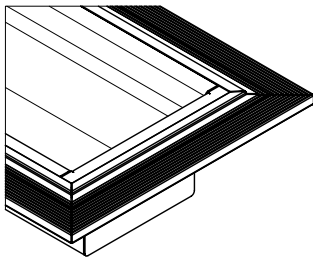

Rolled Over Endplate

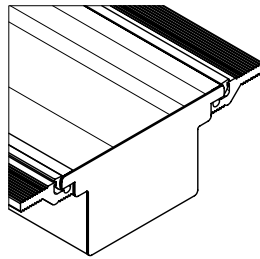

Simple Flat Endplate

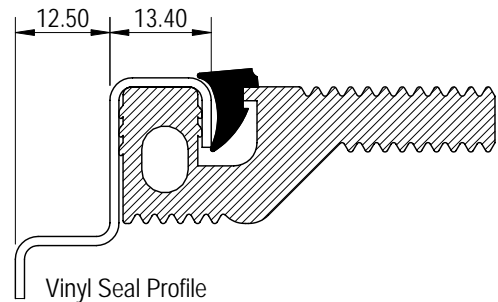

Grate Options (select a grate)

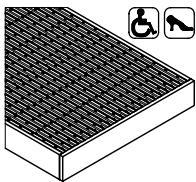

Heelguard 100 Class A
 Heelguard Antislip 100 Class C

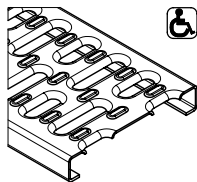

Slotted 100 Class A
 Slotted 100 Class D

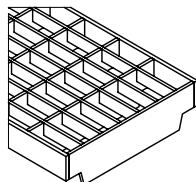

Mesh 100 Class D

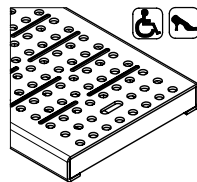

Perforated 100 Class D

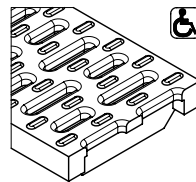

Composite 100 Class D

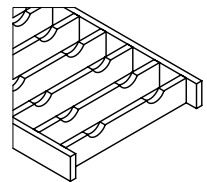

Ladder 100 Class D
 Ladder Antislip 100 Class D



SPECIFICATION CLAUSE

ACO Polycrete Pty Ltd.
134-140 Old Bathurst Road
Emu Plains, NSW 2750
Tel: 02 4747 4000
Fax: 02 4747 4060
e: technical@acoaus.com.au

DRWG# VS1001
www.acoaus.com.au

System 100 - Vinyl Seal with End Outlet

The floor drain troughs are to be ACO Stainless **System 100** as supplied by ACO Polycrete Pty Ltd. All components used within the scope of the system shown on **Drawing No(s)**. _____*. All work should be carried out strictly in accordance with the installation details set out on **Drawing No.** _____*.

All components are to be manufactured from austenitic stainless steel **Grade 304/316/(other)** _____*.

System to be supplied with **Constant Depth/Sloped*** troughs with the overall depths specified as in **Drawing No.** _____*.

Troughs to be supplied complete with **Vinyl Seal** edge profile, in the specified **lengths/layout*** according to **Drawing No.** _____*. Position and nominal size of outlet as detailed in **Drawing No.** _____*.

Grates to be **Part No.** _____*, **with/without*** bolt locking devices.

***Please delete or complete where appropriate.**