	<h1>INSTALLATION DRAWING</h1>	
DRWG# XCHU-AC www.acoaus.com.au	<b>Plastic Pit with Urbanfil Cover: Concrete</b>	
<b>For 330kg Nominal Wheel Load</b>		

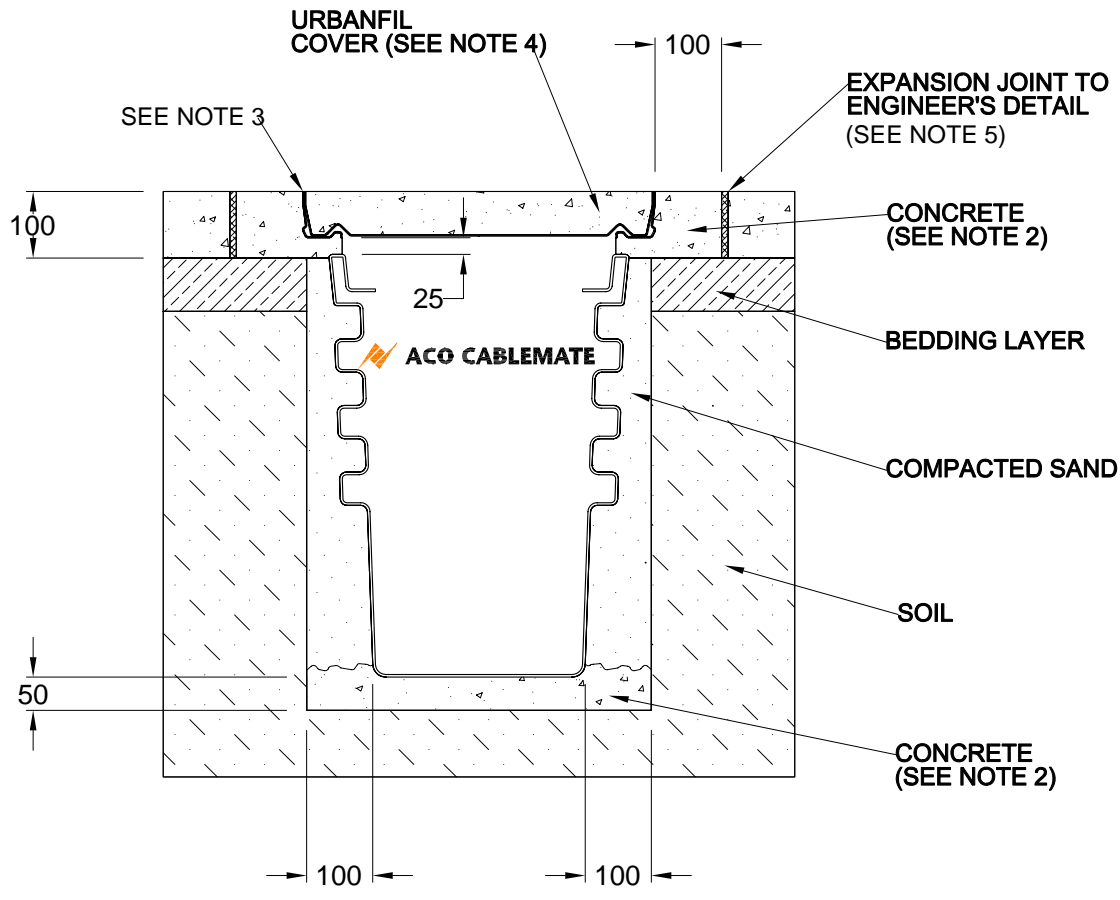

- NOTES:**
1. Specific site conditions may require an increase in these dimensions or reinforcement. It is the customer's responsibility to ensure the concrete encasement is designed for the application. *Engineering advice may be required.*
  2. A minimum concrete strength of 25MPa is recommended. The concrete should be vibrated to eliminate air pockets.
  3. The finished level of the concrete surround must be flush with the top of the frame.
  4. Concrete must be set into the base of the cover prior to pouring concrete surround.
  5. Expansion and crack control joints are recommended to protect the pit and the concrete surround. *Engineering advice may be required.*
  6. Refer to ACO's latest installation instructions for complete details.

	<h1>SPECIFICATION CLAUSE</h1>	ACO Polcrete Pty Ltd 134-140 Old Bathurst Road Emu Plains NSW 2750 Tel: +61 2 4747 4000 Fax: +61 2 4747 4060 e: technical@acoaus.com.au
DRWG# XCHU-AC www.acoaus.com.au	<b>Plastic Pit with Urbanfil Cover</b>	

The electrical/communication enclosures shall be ACO Cablemate plastic pit(s) *type(s) ...and part no(s)....*with Urbanfil cover (for 330kg nominal wheel load) with *clear opening(s) .....* and *part no(s)...*

All materials and components within the scope of this system shall be obtained from this manufacturer and the work shall be carried out as specified in accordance with the manufacturer installation recommendations.